

Mobile Health



Opportunities for use in clinical trials

Mark Ansermino

Assistant Professor

The University of British Columbia

Potential Conflict of Interest

- I have no financial interests
- Funding from Martha Piper Fund
- Radiation from cell phones may be harmful



What is mHealth?

- **mHealth** (*n*) – *the delivery of health care services via mobile communication devices*



The Adoption of Mobile Technologies

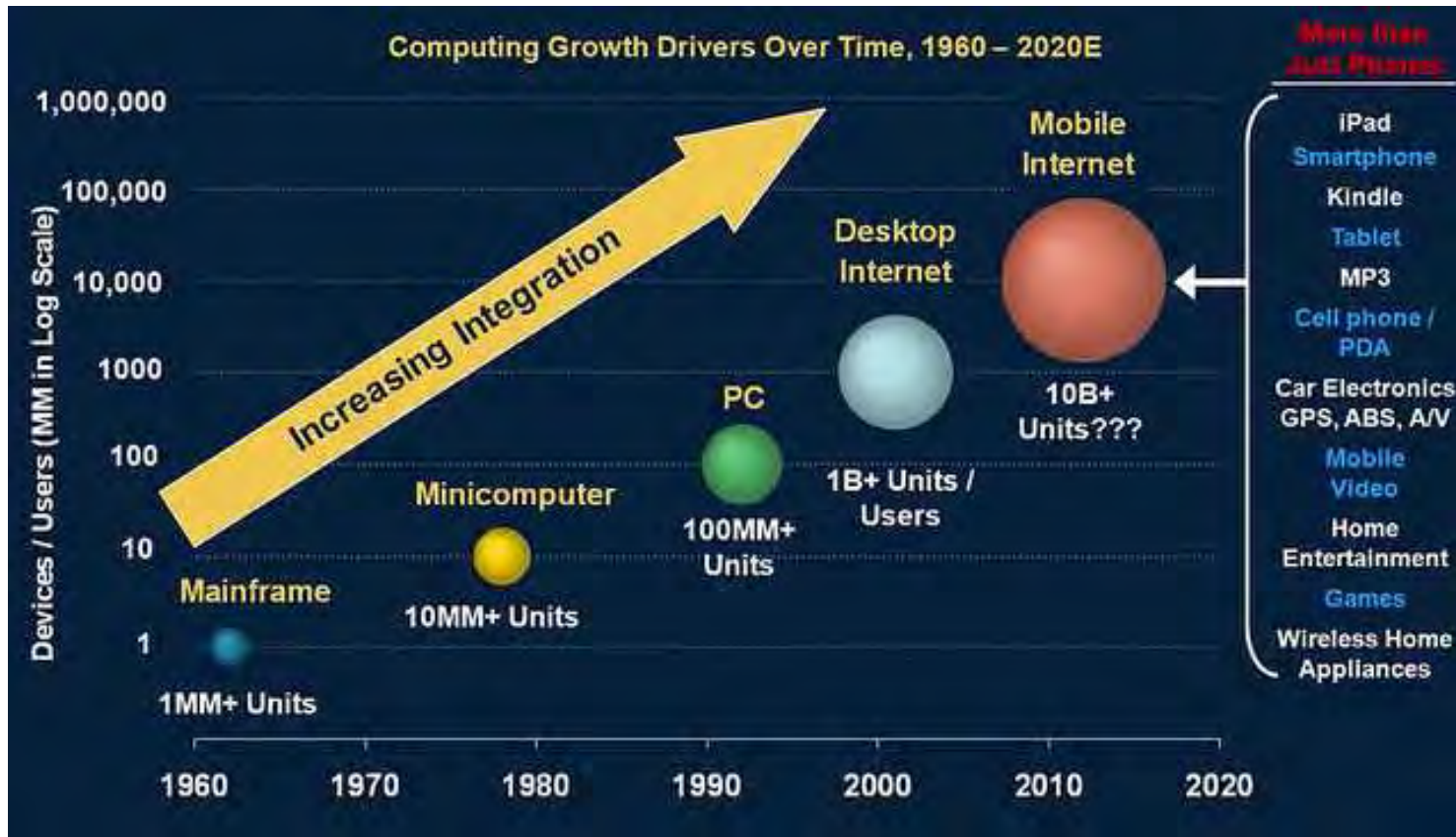

Globally, 6 in 10 adults have a cell phone contract *WHO*

More than 1 billion apps downloaded *Apple*

Teens love to text (3000 times month pp) *Nielsen Report*





Health at the app store..



Over 8000 health apps on iTunes

\$2.1 billion in 2011

\$40 billion in 2014

MobileMarketingWatch

The Potential for mHealth

- **New paradigm:** “You used to bring the patient to the doctor. Now you take the doctor, hospital, and entire healthcare ecosystem to the patient.” *Rajeev Kapoor, executive at Verizon*
- **Avoid Visits:** 30 % of office visits could be avoided with remote monitoring, email or text messaging *PwC*
- **e-visit:** e-visits replace in-office visits in 40% of the 2,531 cases *Mayo Clinic*

SMS (Short Message Service)

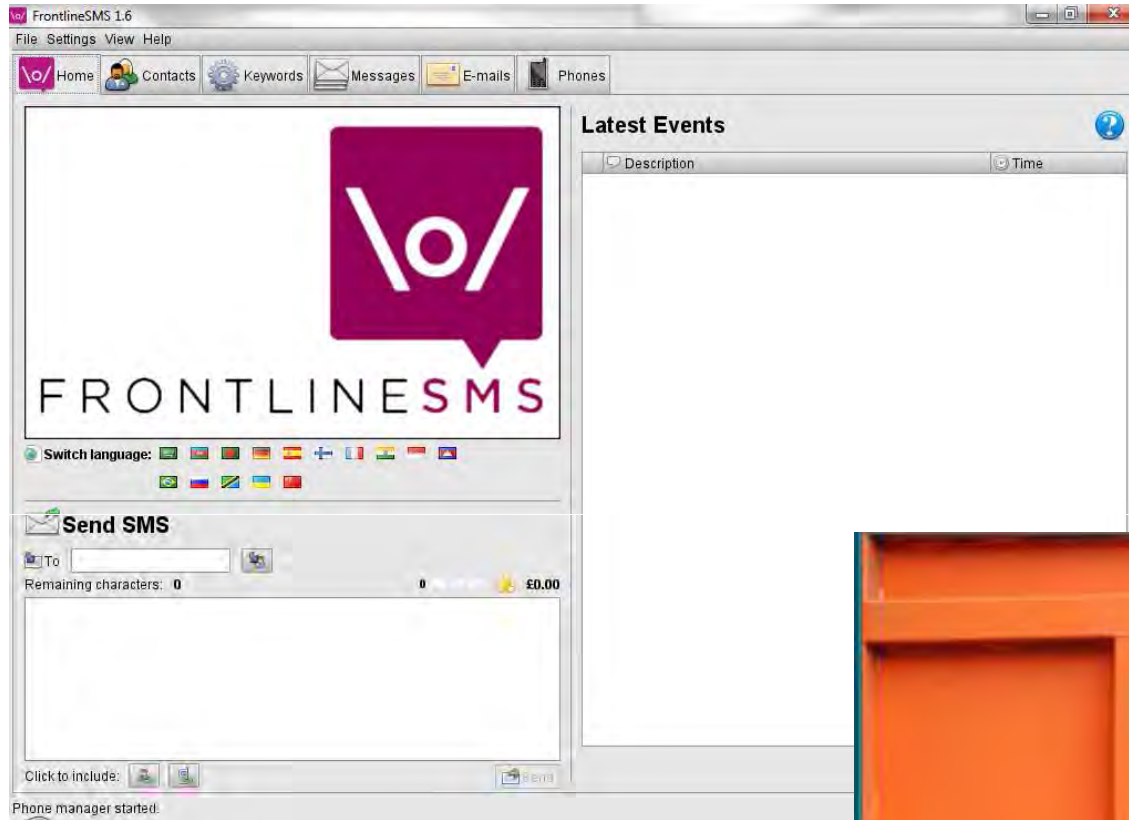

SMS – medication compliance

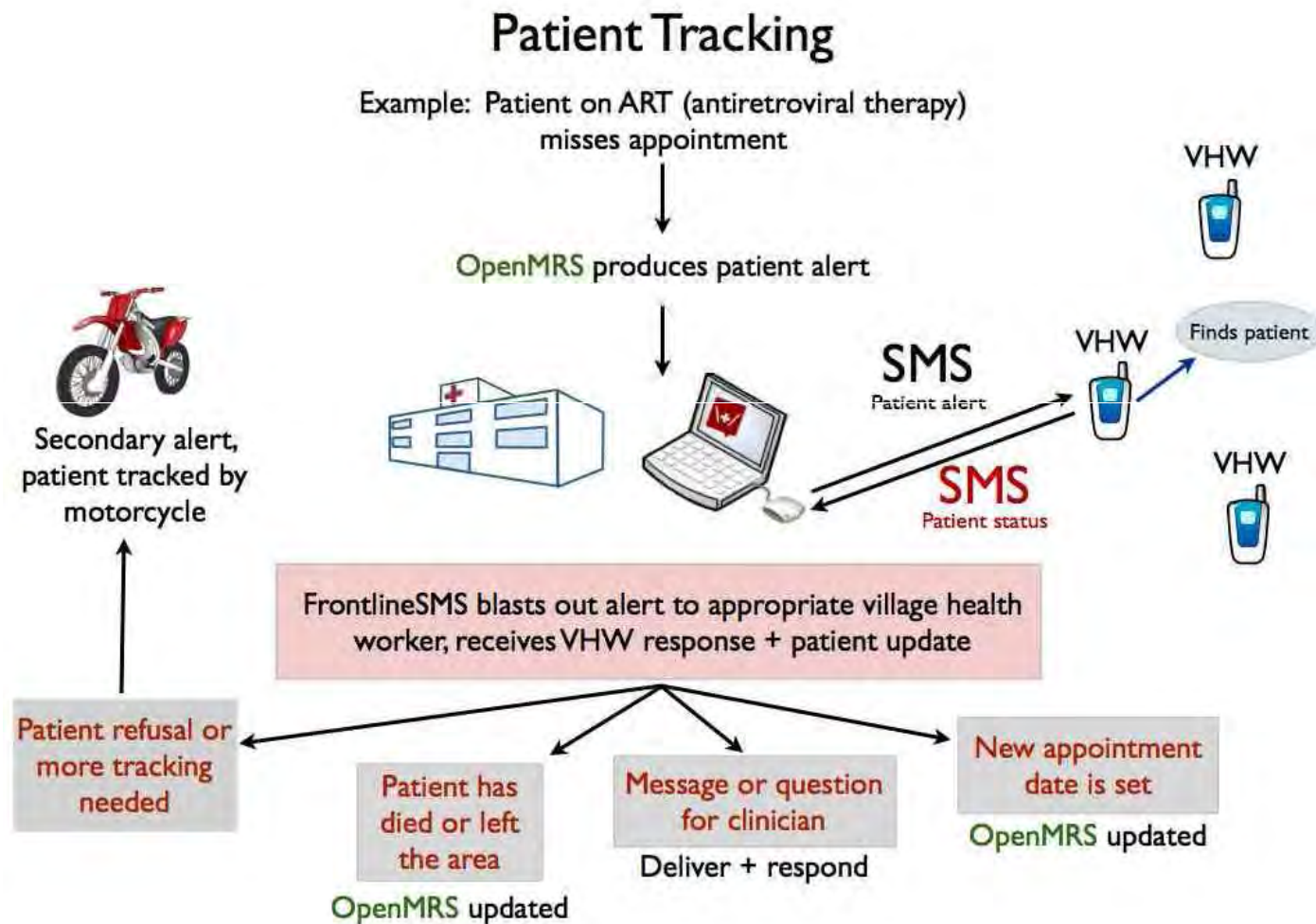

It really works!

Lester RT, Ritvo P, Mills EJ, et al.

Effects of a mobile phone short message service on antiretroviral treatment adherence in Kenya (WelTel Kenya1): a randomised trial.

The Lancet. 2010;376(9755):1838-1845.

Sensing Makes Sense



Weight

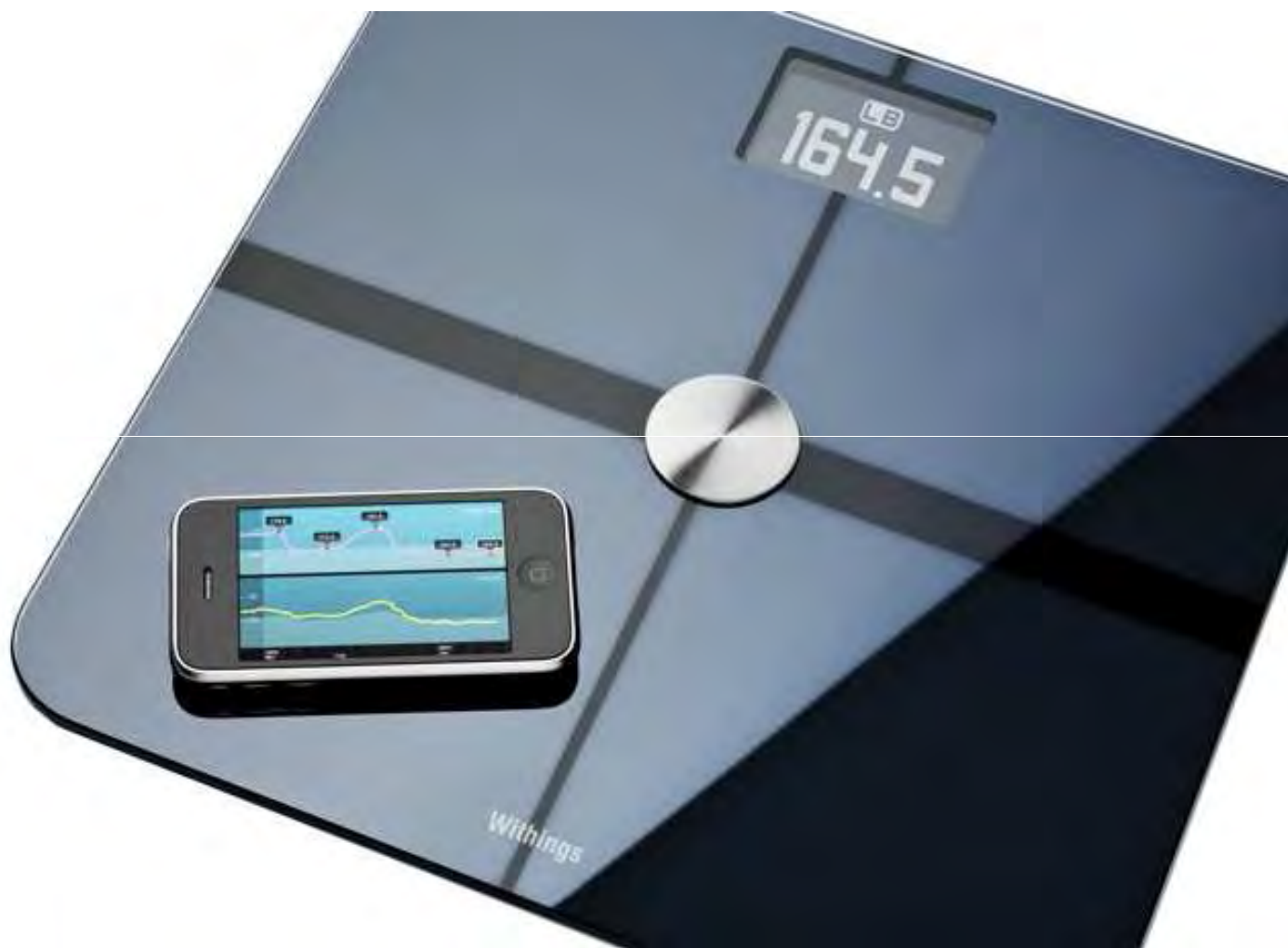

Blood Pressure



ECG



The drug is the plug





Phone Oximeter

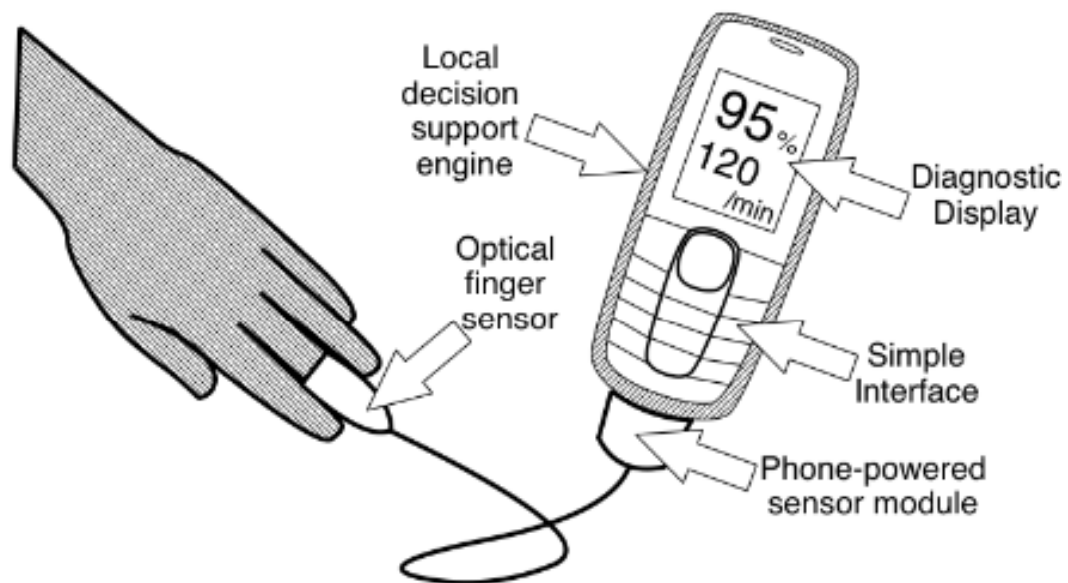

Main Screen

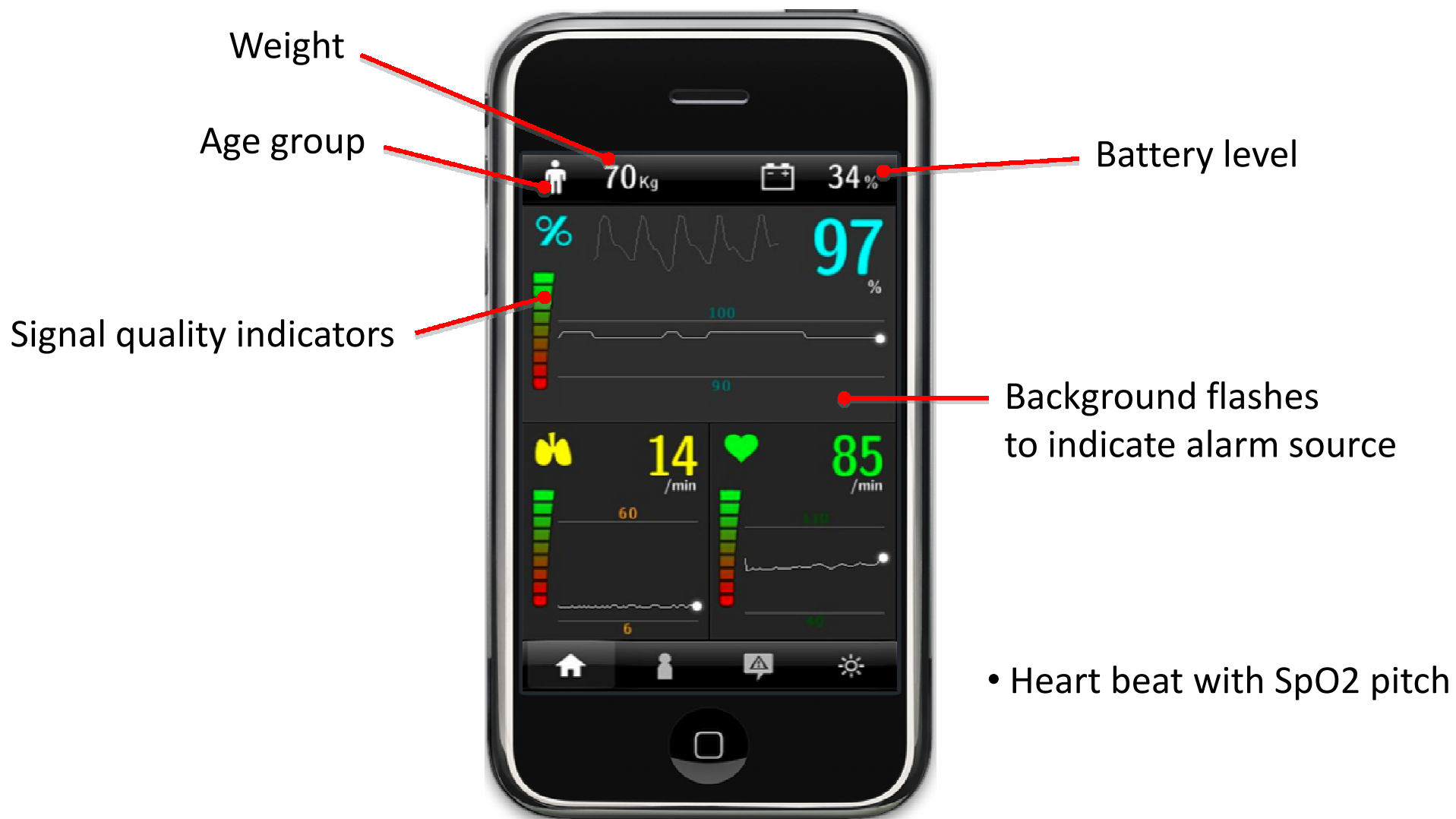

Configuration Screen

The image shows a smartphone screen with a configuration menu. The menu is titled 'Settings' and has three icons at the top: a person, a person with a checkmark, and a person with a plus sign. The menu items are:

- Weight: 4, 5, 6 Kg
- %: 99, 100, %
- 89, 90, 91
- Heart icon: 159, 160, /min
- 79, 80, 81
- Lungs icon: 59, 60, /min
- 6, 7
- 6, 7, 8 min

Red arrows point from the following text labels to the corresponding elements on the screen:

- Weight: points to the weight selection area.
- Alarm limits: points to the heart rate and respiratory rate selection areas.
- Age Groups: points to the person icon at the top right.

• Selecting Age Group will reset settings to age specific defaults

Decision Support Screen

Current alarms

Past alarms

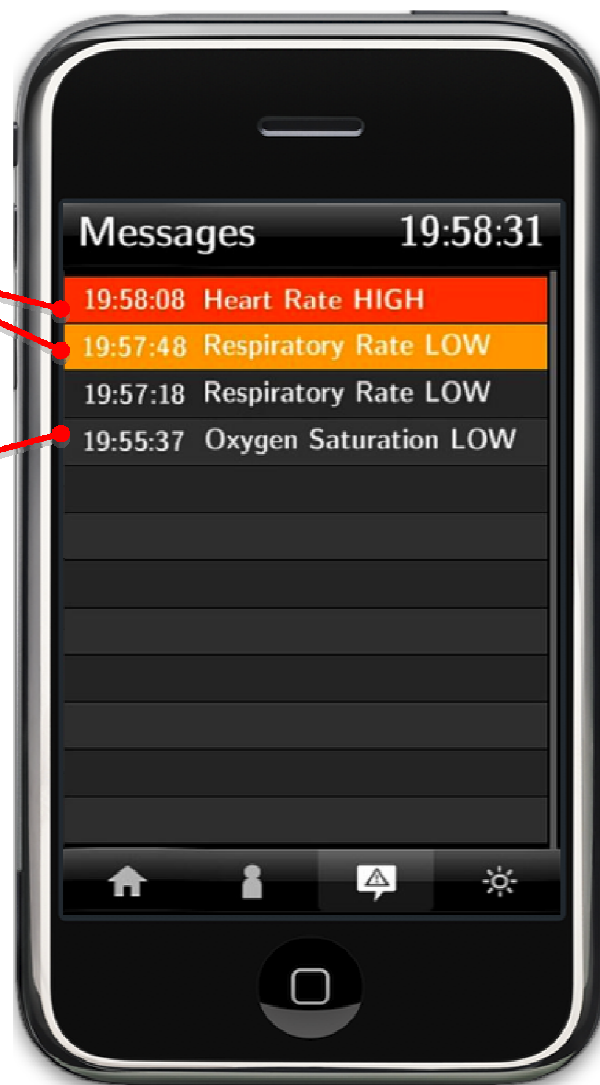

- Forward chaining inference
- Three audible alarm levels
- Alarms silenced by touch
- 10 second initial trigger delay
- 60 second repeat delay

Infant Pneumonia (ALRI)



Two million deaths a year

No Treatment

Inappropriate treatment

Inadequate treatment

Infant Pneumonia



Simple Treatments!

SpO₂ will change the world!

- Impact
 - Early diagnosis (screening)
 - Lay health worker diagnosis
 - Follow response to antibiotics
 - Reduced antibiotic use
 - Early referral
 - Manage oxygen therapy

The Problem...



\$\$\$\$

?

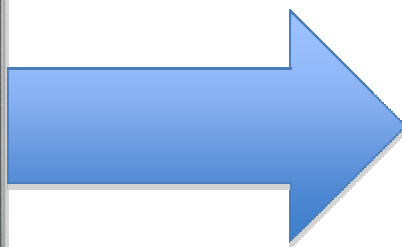

\$

\$1 Audio Oximeter

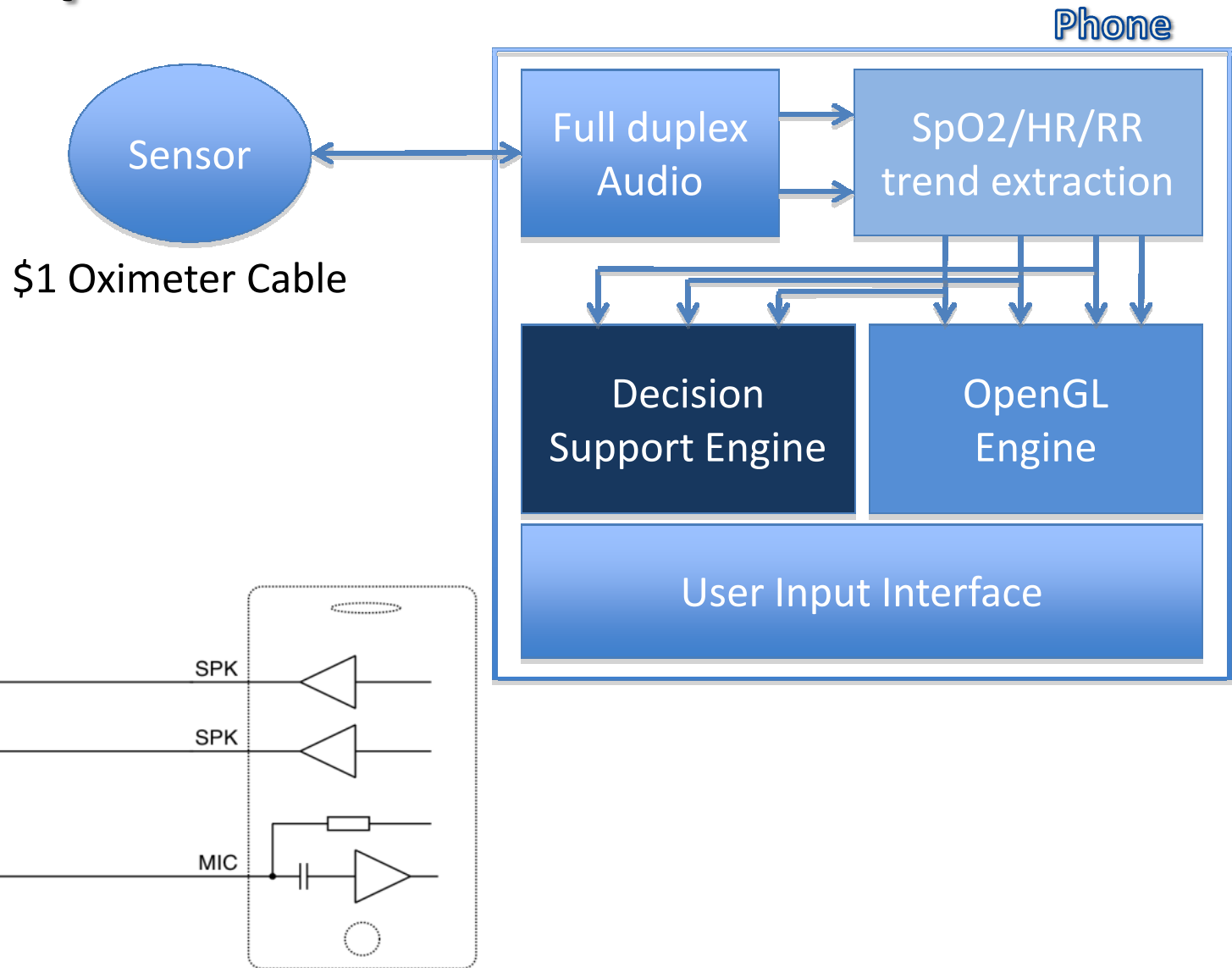

Audio Oximeter

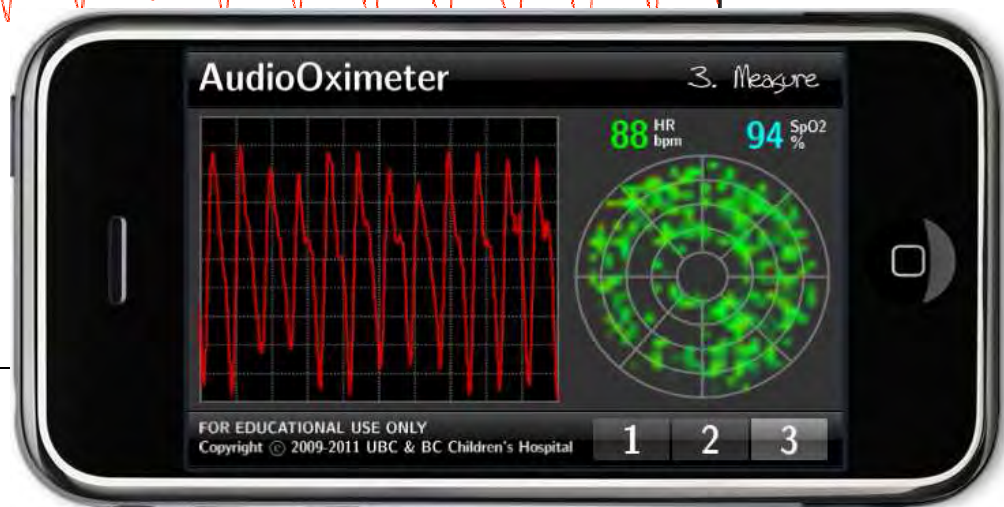
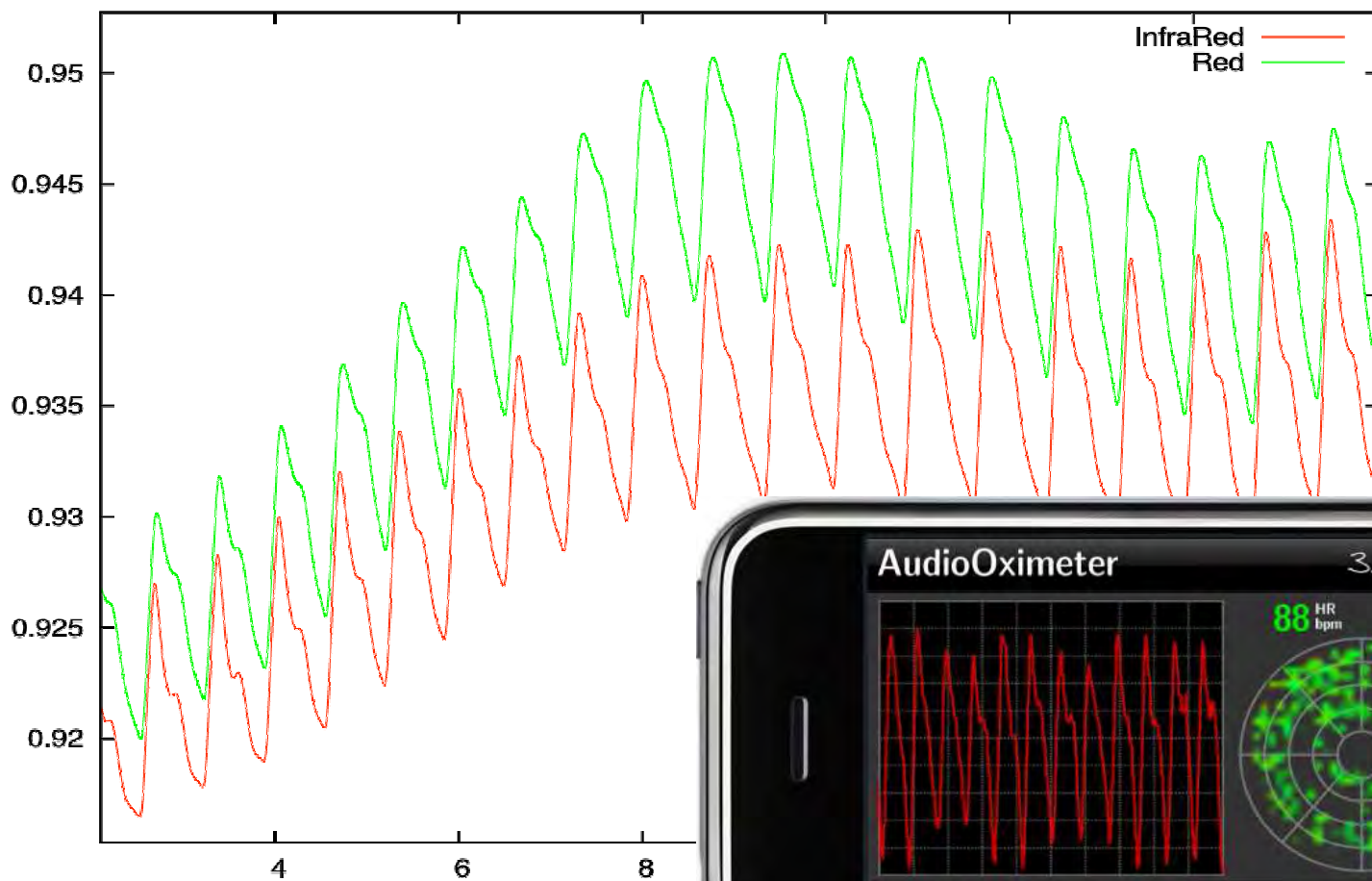

The Future..?

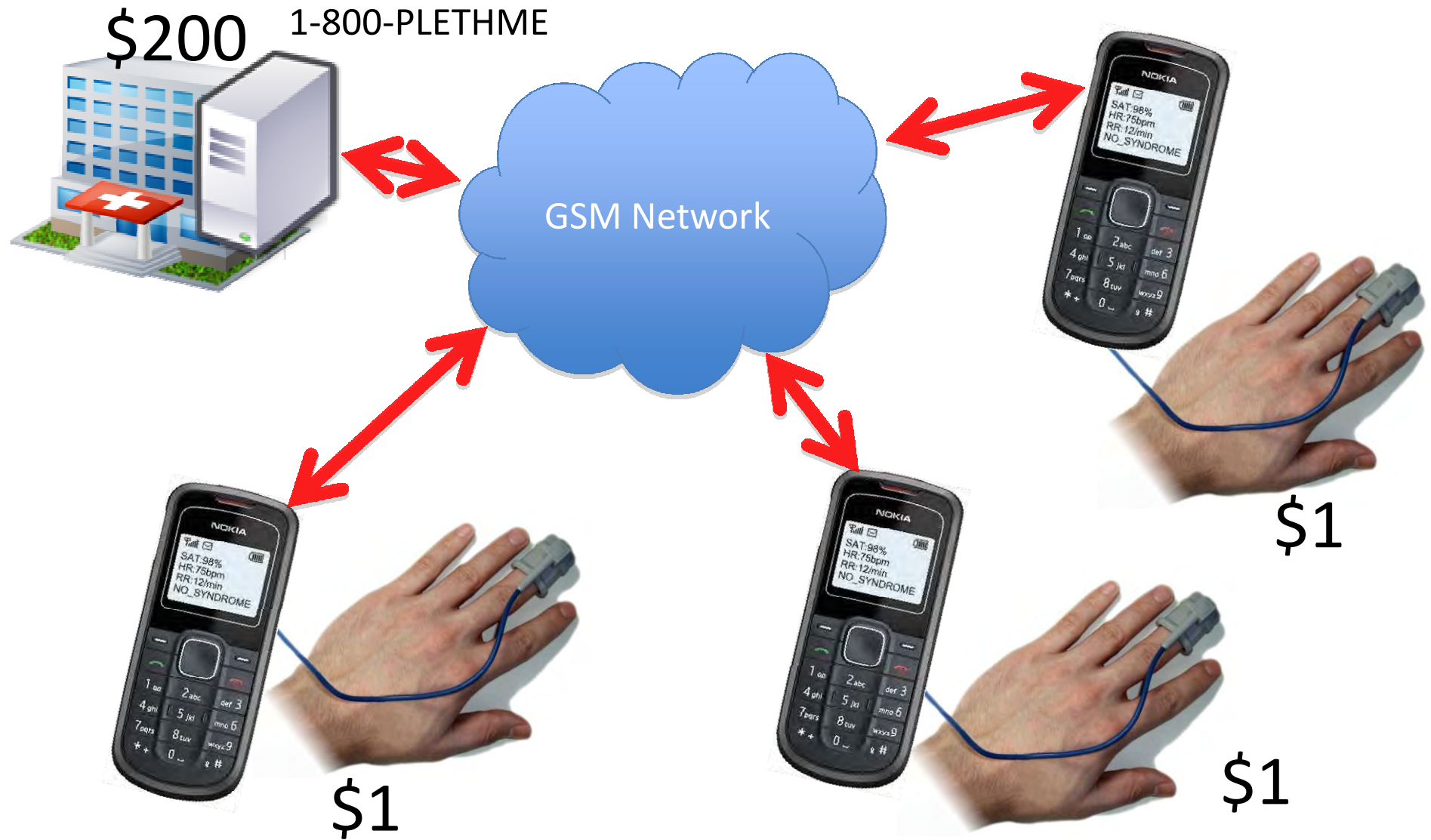

Regulation

- Ultra-low cost oximetry an oxymoron
 - Cost of compliance



mansermino@cw.bc.ca

phoneoximeter.org

